



RainPoint[®]
More Than Water Saving

* KEEP THIS MANUAL
FOR FUTURE REFERENCE.

USER MANUAL

1-Zone WiFi Water Timer with WiFi Hub

Model NO.:
TTV103WRF+TWG004WRF

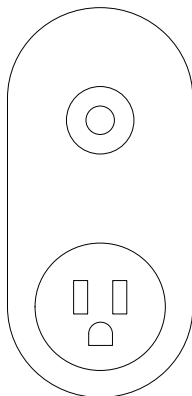
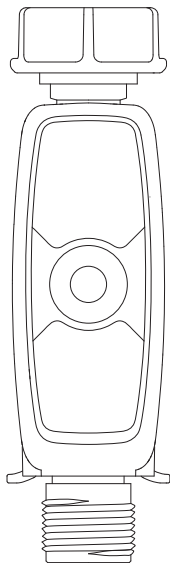

Customer Support:

Web: www.rainpointonline.com

Email: service@rainpointonline.com

WhatsApp: +1626-780-5952

US toll free: +1 833-381-5659

(Mon-Fri: 9: 30 AM-5: 30 PM PST)

DE toll free: +49 800-182-0576

(Mon-Fri: 9: 00 AM-5: 00 PM CET)

UK toll free: +44 800-808-5337

(Mon-Fri: 9: 00 AM-5: 00 PM CET)

WELCOME TO RAINPOINT

Thank you for choosing RAINPOINT 1 Zone WiFi Water Timer with WiFi Hub!

After using the RainPoint WiFi water timer, you'll find it easier, faster and more convenient than ever before! You are able to schedule, manually operate, auto watering and monitor flow just with your smart phone. When the timer is connected to the hub and your WiFi, it can synchronize the weather forecast from internet to automatically update and adjust your watering plan. The timer works much like other WiFi devices: as long as your phone can access to the internet, you can connect the device and control your timer no matter where you are.

Whatever your outdoor watering needs, RainPoint provides best-in-class irrigation products to help you more effectively manage and control your watering!

Let's start to enjoy the wonderful smart irrigation life!

More product information and user guide will happen on



Have Questions?

Email: service@rainpointonline.com

WhatsApp: +1626-780-5952

US Free Hotline (English): +1 833-381-5659 (Mon-Fri: 9:30 AM-5:30 PM PST)

DE Free Hotline (English/Deutsch): +49 800-182-0576 (Mon-Fri: 9:00 AM-5:00 PM CET)

UK Free Hotline (English): +44 800-808-5337 (Mon-Fri: 9:00 AM-5:00 PM CET)

CONTENTS -----

1. INTRODUCTION	01
CONTENTS IN THE BOX	01
2. PRODUCT OVERVIEW	02
TTV103WRF 1 Zone WiFi Water Timer	02
TWG004WRF WiFi Hub	03
FEATURES OVERVIEW	04
3. INSTALLATION	06
4. APP PROGRAMMING	12
APP HOME SCREEN	12
WIFI WATER TIMER	13
Device Parameter	13
Manual Watering	15
Watering Plan & Manual Rain Delay	16
WiFi Soil Sensor & Water Flow Meter	20
WIFI SOCKET	21
SMART AUTOMATION	23
HOME MANAGEMENT	26
5. RESET THE DEVICE	27
6. TROUBLESHOOTING	28
7. WARRANTY POLICY	32
8. CUSTOMER SUPPORT	33
9. FCC NOTICE	34

INTRODUCTION

CONTENTS IN THE BOX

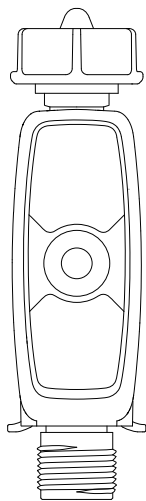
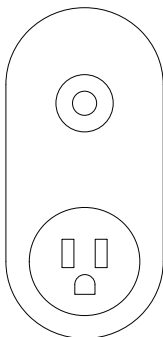
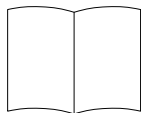
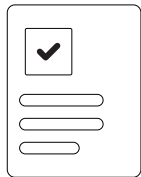
**A****B****C****D**

A. 1 x TTV103WRF 1 Zone WiFi Water Timer

B. 1 x TWG004WRF WiFi Hub

C. 1 x Quick Guide

D. 1 x User Manual

PRODUCT OVERVIEW

TTV103WRF 1 Zone WiFi Water Timer

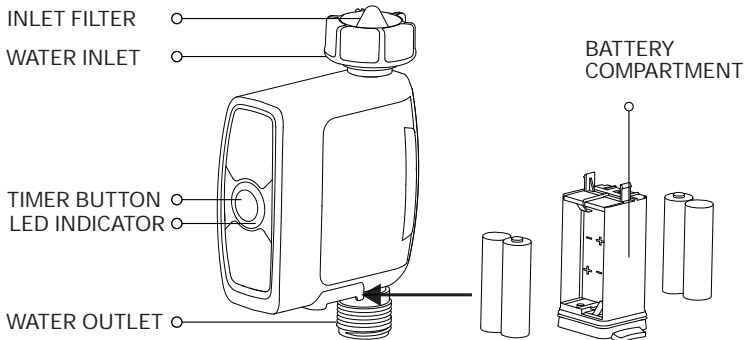

ITEM	SPECIFICATION
Range Between WiFi Hub and Timer	160 ft in the open area without interference
Working Water Pressure	0.5 bar to 8 bar (7.25-116.03PSI)
Temperature Operating Range	3°C - 50°C (37°F-122°F)
Powered By	4 * AA alkaline batteries (not included)
Waterproof Rating	IP54



For outdoor use with cold water only.

Keep away from freezing. In freezing weather, the timer should be placed indoors.

Used up or dead batteries must be removed from the timer and disposed of properly.

TWG004WRF WiFi Hub

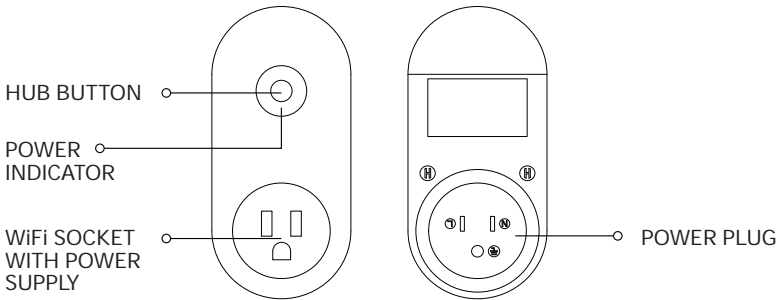

ITEM	SPECIFICATION
Range Between WiFi Hub and Router	160 ft in the open area without interference
Temperature Operating Range	3°C-40°C (37°F-104°F)
WiFi Frequency Band	2.4GHz only
Input	100-240V 50Hz 16A



For indoor use only.

Only applicable to 2.4GHz WiFi. If your router is a dual-band router, please independently enable the 2.4GHz WiFi band and name it differently from the 5GHz WiFi band.

FEATURES OVERVIEW

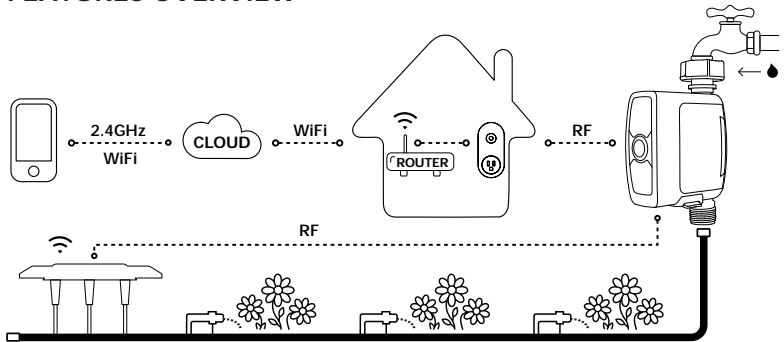

- 1) **WiFi Remote Control:** Connect with 2.4GHz WiFi, set and check irrigation schedule by APP.
- 2) **WiFi Socket:** The WiFi Hub can be used as a WiFi socket.
- 3) **Manual Watering:** Manually turn on/off watering and set watering time.
- 4) **Watering on Schedule:** The timer can set up to 3 separate watering programs every day. Each watering program has different start time and watering duration.
- 5) **Automatic Watering:** ① When the WiFi timer is connected to the WiFi soil sensor (not included), it can automatically irrigate or stop according to the soil temperature and humidity data; ② When you locate the home address for the timer, the APP will automatically synchronize the local weather information, and the timer can be automatically executed according to the weather trigger conditions you set.
- 6) **Rain Delay:** Manual Rain Delay and Automatic Rain Delay.
- 7) **Water Flow Meter:** Built-in water flow meter to track water usage in the last 10 days.

- 8) **Two Watering Modes:** Irrigation mode and Mist mode.
 - 9) **Co-management with family:** Home Management allows you to add family members and give them permissions to manage the irrigation of your home garden together.
 - 10) **Low Battery and Water Leak Alarm:** APP will send you alert messages when low battery or product failure.
 - 11) **One WiFi hub can pair with maximum 4 WiFi water timers.**
 - 12) **One WiFi water timer can pair with 1 WiFi soil sensor *.**
- Only applicable to 2.4GHz WiFi.
 - Only compatible with TTV103WRF 1-zone WiFi water timer and TTV203WRF 2-zone WiFi water timer.

INSTALLATION



Setup Video



Customer Support

Tips:

Please scan the QR code or search the link for setup video or customer support to install the device quickly.

Setup Video:

www.youtube.com/@rainpoint

Customer Support: www.rainpointonline.com/pages/support

STEP 1: INSTALL APP ON YOUR PHONE

RainPoint-Tuya



1) Download the RainPoint-Tuya App

Search for "RainPoint-Tuya" on Google Play/App Store or scan the QR code to download the RainPoint-Tuya APP.

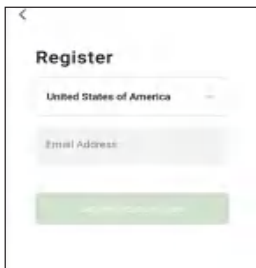

2) Register your RainPoint account

Open your RainPoint-Tuya APP, select **Sign UP**. Follow the prompts to register a RainPoint account with your email or mobile number.

Note: Ensure your country/region details are correct at this stage.

You may be prompted to allow access to your location. This allows the app to show weather information, and can still function if you choose to opt out.

STEP 2: CONNECT THE WIFI HUB

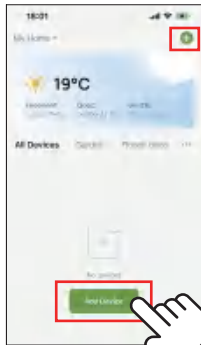

- 1) Plug your WiFi Hub to an **indoor power source** near your WiFi router and the outdoor location of your timer.
- 2) Open RainPoint App and tap **"Add device"** or **"⊕"** to add a new device.
- 3) Tap **"Smart Irrigation"** and then select **"Irrigation Hub"**.

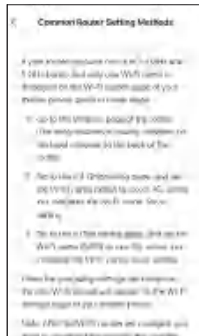
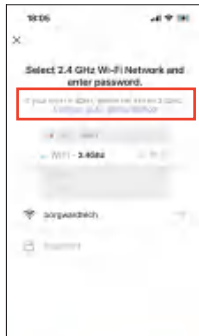

- 4) Select **2.4GHz WiFi**, and enter the password.

Tips: If your router is a dual-band router, and you cannot identify the 2.4GHz or 5GHz WiFi, please tap the blue words **"Common router setting method"** to name the 2.4GHz WiFi differently, then you can select it individually.



The device is **only** connected to a separate **2.4GHz WiFi**, if you need help during the device WiFi connection, please feel free to contact us.
Email: service@rainpointonline.com
WhatsApp: +1626-780-5952

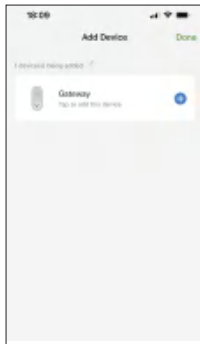

- 5) Press and hold the WiFi hub button until the power indicator blink rapidly (**2 times per second**). Then select "**confirm indicator rapidly blink**" and tap "**Next**". The APP will search and pair your WiFi Hub automatically.
- 6) After the connection is successful, the color icon of irrigation hub will be displayed on the APP home screen.

Tips:

If the indicator doesn't blink rapidly (2 times per second), please refer to the "**RESET THE DEVICE**" section of this manual to reset the WiFi hub and make the hub indicator blink rapidly !

STEP 3: CONNECT THE WIFI TIMER

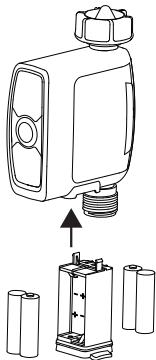

- 1) Insert **4 new AA alkaline batteries** into the battery compartment of the timer. Restore the battery compartment and make certain it is secured.

WARNING:

- Please use only alkaline batteries.
- Do not mix old and new batteries.
- Batteries are to be inserted with the correct polarity.
- Exhausted batteries are to be removed from the product.
- Please remove the battery from long-term no use.

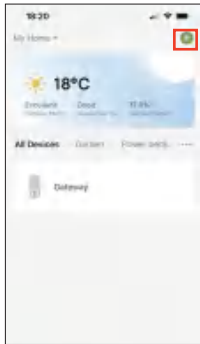

- 2) Return to the APP home screen, and tap "+" to add the WiFi timer.
- 3) Tap **"Smart Irrigation"** and select **"WiFi Water Timer"**.

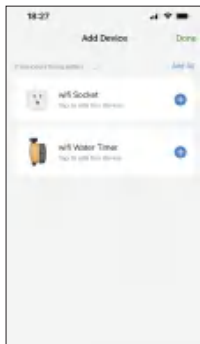

- 4) Press and hold the button on the timer until the LED indicator blink rapidly (**2 times per second**). Then select **"confirm indicator rapidly blink"** and tap **"Next"**. The APP will search and pair your WiFi timer automatically.
- 5) Tap "+" on the right to add the wifi water timer, and tap **"Done"**.

Tips: If the indicator doesn't blink rapidly (2 times per second), please refer to the **"RESET THE DEVICE"** section of this manual to reset the WiFi timer and make the timer indicator blink rapidly.

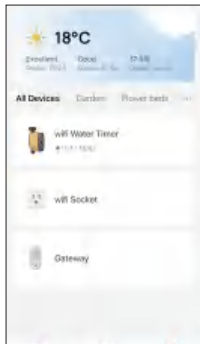
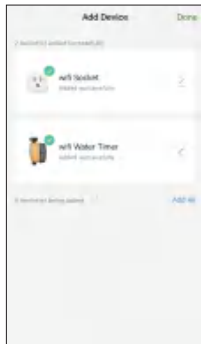

6) After the connection is successful, the color icons of WiFi timer and WiFi socket will be displayed on the APP home screen.

Tips: If necessary, **three additional WiFi timers can be added to the RainPoint APP through a WiFi hub.** A separate WiFi timer is available on Amazon.

STEP 4: INSTALL THE WIFI TIMER

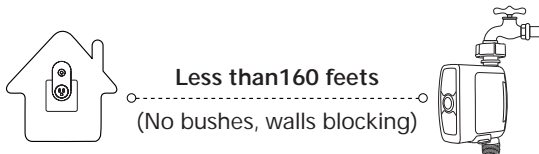
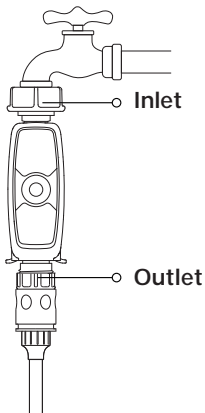

1) Attach the timer inlet parallel to the outdoor faucet/spigot and hand tighten only. From the timer outlet connect a drip irrigation system or a garden hose.

⚠ WARNING:

- The WiFi timer can only be used for cold water.
- The WiFi timer uses a 433mHz RF connection to communicate with the WiFi Hub, and must be within a 160ft range, line of sight, of the WiFi Hub. **If there are walls, iron gates or bushes blocking, please shorten the distance between them to better receive the signal.**
- Soil will absorb WiFi and RF signals, **the best location of the timer is on the faucet 4 to 8 feet (1.2 to 2.4 meters) above the ground.**
- Do not place the WiFi timer in an underground valve box or anywhere your WiFi and RF signal will be obstructed.
- Under freezing weather, the water timer should be removed from the tap and placed properly indoor to avoid any danger of freezing.

STEP 5: TEST BEFORE USE

Congratulations, you have completed the connection and installation of the WiFi water timer. Please test whether the internal valve of your water timer is normal before using it.

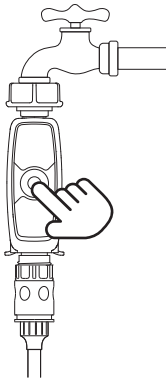

- 1) Keep the faucet turned off.
- 2) Press the button of the timer, with a "click" sound, the valve inside the timer opens for manual watering. After a few seconds, press the button again, the "click" will sound again, and the valve will close.
- 3) Turn on the faucet a little bit, press the button of the timer to check if the water is flowing out or not. If yes, the valve is normal, please use it with confidence! If not, please repeat the above steps several times.

The test is over, everything is normal, please keep the faucet fully turned on!

Note: When testing, please keep away from the water outlet of the timer to avoid being splashed and wet.

APP PROGRAMMING

APP HOME SCREEN

Local Weather Forecast

Get your local weather forecast from website to realize intelligent watering.

All Devices

A check list of all the devices you have connected. Tap the icons to enter the operation page of devices you have added to program the operation schedule of the device.

Scene

On the "Scene" screen, there is "Tap-to-Run" and "Automation" functions. You can automate multiple smart products by setting conditions and tasks.

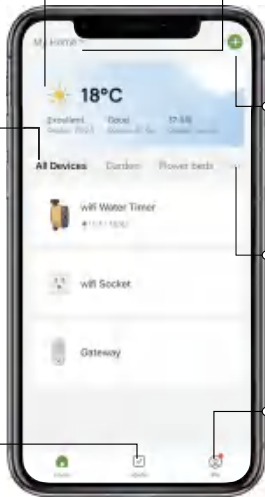

Home Management

You can locate your home, customize the home name and add family members. It is convenient for you to manage irrigation schedules for different residences.

Add Devices

You can add multiple RainPoint devices on the APP to create a smart home irrigation system.

Room Management

Room Management is for indoor automatic irrigation system in different room.

Me

On the "Me" screen, there is "Message Center" and "FAQ & Feedback" functions. You will receive water leak and low battery alerts on "Message Center". And you can get FAQ and report issue on "FAQ & Feedback".

WIFI WATER TIMER

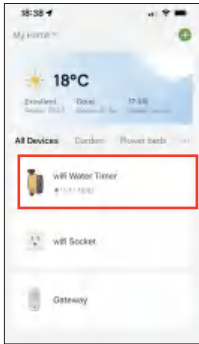

Tap the WiFi water timer on the all devices list of APP home screen. It will display all the parameters and functions of the timer manually set on the APP.

Note: The WiFi timer will follow and perform the preset watering schedule after application set successfully, even if the phone or device loses network connection.

Device Parameter

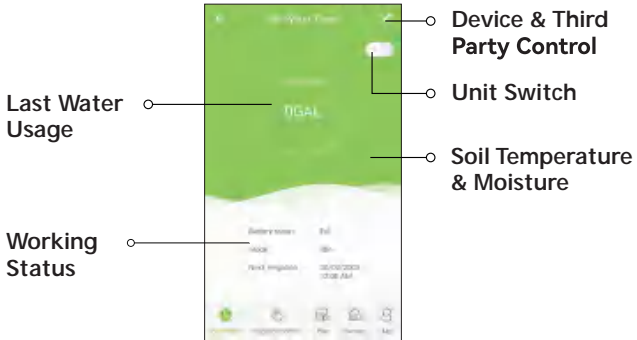

- **Device & Third Party Control**

Tap "  " on the top right of the screen, you will enter the page for device information and third-party control.

- **Unit Switch**

Tap "'F/°C"' switch, it will change the unit (°F/°C) of soil temperature and the unit (GAL/L) of water usage.

- **Last Water Usage**

The WiFi water timer has built-in water flow meters, it will display the last water usage on the screen.

- **Soil Temperature & Moisture**

Paired with the RAINPOINT WiFi soil sensor (sold separately), it can also display soil temperature and moisture. If the soil moisture is higher than the water prohibition level set on the soil sensor, the APP background color will change to red.

- **Working Status**

Display the battery level of the timer, the current working mode and the time of the next watering.

How to get third-party control / voice control?

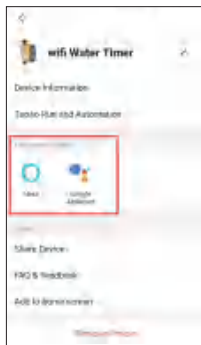

If you have an **Amazon Alexa** or **Google Assistant**, please tap the icon "  " in the upper right corner of the device page, select a third-party voice control device you own, then tap the operation guide, and follow the instructions to connect your WiFi water timer to the voice control device. After successfully connecting, you can control the WiFi water timer by voice.

Note: The WiFi water timer can only perform simple voice commands, such as **"turn on or turn off"** and the voice commands should only be **English**. If you have any questions or suggestions about this feature, please feel free to contact us.

US Free Hotline (English): +1 833-381-5659

(Mon-Fri: 9: 30 AM-5: 30 PM PST)

DE Free Hotline (English/Deutsch): +49 800-182-0576

(Mon-Fri: 9: 00 AM-5: 00 PM CET)

UK Free Hotline (English): +44 800-808-5337

(Mon-Fri: 9: 00 AM-5: 00 PM CET)

Email: service@rainpointonline.com

WhatsApp: +1626-780-5952

Manual Watering

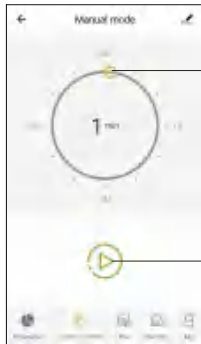

Manual Watering Duration

Move the hollow green circle on the dial to set the desired manual watering duration (0-60min).

Manual Watering Duration

Tap ► to start watering and ⏸ to stop.

Watering Plan & Manual Rain Delay

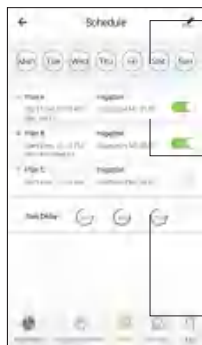

Watering Day Of The Week

Each plan has a **specific color punctuation**. The punctuation in a specific color on the day of the week indicates that there is a corresponding watering plan for that day.

Plan A/ Plan B/Plan C

The WiFi timer can set 3 different watering plans every day. Each watering plan can be set with different start time, duration and watering day (frequency). Slide the switch of the watering plan to turn it on or off.

Manual Rain Delay

Rain delay applies to rainy days or other weather that causes high soil moisture. During the rain delay, the timer stops watering. After the rain delay ends, the timer will be executed according to the next watering plan. **The timer can set 24/48/72 hours of rain delay.**

How to set the watering plan?

- 1) Tap Plan A/ Plan B/ Plan C on the plan screen of the WiFi water timer.
- 2) Each watering plan has two watering modes: **Irrigation Mode and Mist Mode.**

These two modes do not refer to the difference in the water output of the timer, **but the different settings of the watering frequency and duration.**

Irrigation Mode: Watering at longer intervals.

Mist Mode: Watering at shorter intervals.

Irrigation Mode (Irrigation by quantity)

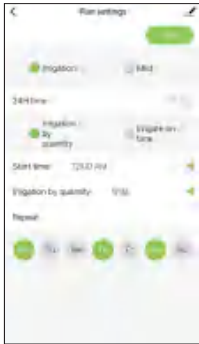

- 3) Tap **Irrigation Mode**.
- 4) Use the **24H** time switch to toggle between 24hr and AM/PM time.
- 5) Click to select **Irrigation by quantity**.
- 6) Click the green arrow of **Start time** on the right to open the clock and set a start time.
- 7) Click the green arrow of **Irrigation by quantity** on the right to set the continuous watering volume (from 1L to 10000L, from 1gallon to 2641 gallons).
- 8) Select the days to repeat watering every week as needed.
- 9) Save your settings.

For example: The picture on the left shows that the WiFi water timer will water for 514L in irrigation mode. The start time is every Monday, Thursday and Saturday at 12: 00 am.

Irrigation Mode (Irrigation on time)

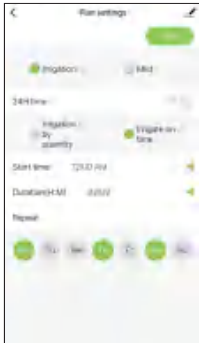

- 3) Tap **Irrigation Mode**.
- 4) Use the **24H** time switch to toggle between 24hr and AM/PM time
- 5) Click to select **Irrigation on time**.
- 6) Tap the green arrow of **Start time** on the right to open the clock and set a start time.
- 7) Tap the green arrow of **Duration(H:M)** on the right to set a watering duration (from 0 hour 0 minute to 11 hours to 59 minutes).
- 8) Select the days to repeat watering every week as needed.
- 9) Save your settings.

For example: The picture on the left shows that the WiFi water timer will water for 2 hours and two minutes in irrigation mode. The start time is every Monday, Thursday and Saturday at 12: 00 am.

Mist Mode (Spray by quantity)

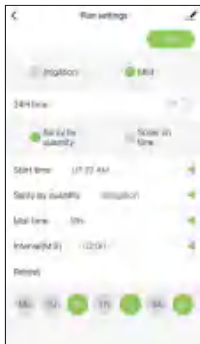

- 3) Tap **Mist Mode**.
- 4) Use the **24H** time switch to toggle between 24hr and AM/PM time.
- 5) Click to select **Spray by quantity**.
- 6) Tap the green arrow of **Start time** on the right to open the clock and set a start time.
- 7) Tap the green arrow of **Spray by quantity** on the right to set the overall water volume of the misting program (from 1L to 10000L, or from 1 gallon to 2641 gallons).
- 8) Tap the green arrow of **Mist time** on the right to set the duration for each misting.
- 9) Tap the green arrow of **Interval(M:S)** on the right to set the interval time between each misting.
- 10) Select the days to repeat watering every week as needed.
- 11) Save your settings.

For example: The picture on the left shows the WiFi water timer will water for 59 seconds and then rest for 2 minutes in mist mode cyclically. Until it runs out 555 gallons of water, it will start watering at 7:30 in the morning every Wednesday, Friday and Sunday.

Mist Mode (Spray on time)



- 3) Tap **Mist Mode**.
- 4) Use the **24H** time switch to toggle between 24hr and AM/PM time.
- 5) Click to select **Spray on time**.
- 6) Tap the green arrow of **Start time** on the right to open the clock and set a start time.
- 7) Tap the green arrow of **Misting Period(H:M)** on the right to set the overall duration of the misting program (from 0 hour 0 minute to 11 hours to 59 minutes).
- 8) Tap the green arrow of **Mist time** on the right to set the duration for each misting.
- 9) Tap the green arrow of **Interval(M:S)** on the right to set the interval time between each misting.
- 10) Select the days to repeat watering every week as needed.
- 11) Save your settings.

For example: The picture on the left shows the WiFi water timer will water for 59 seconds and then rest for 2 minutes in mist mode cyclically. The cycle lasts for 2 hours, starting at 7:30 in the morning every Wednesday, Friday and Sunday.

WiFi Soil Sensor & Water Flow Meter



WiFi Soil Sensor (sold separately, not included)

If you have a Rainpoint WiFi soil sensor, you can pair it with your Rainpoint WiFi water timer and WiFi hub.

One WiFi timer can pair with one WiFi soil sensor.

And the soil temperature and moisture data monitored by the soil sensor will be displayed on your Rainpoint APP.

The soil sensor can also control the watering schedule of the timer. When the soil moisture is higher than the water prohibition level set on the soil sensor, the timer automatically interrupts the watering plan and stops watering until the soil moisture decreases.



Water Flow Meter

Each WiFi water timer has a built-in water flow meter.

It will show you the daily water consumption in the last few days and help you quantify the daily water consumption to save water.

Note: How to switch the unit of soil temperature and moisture and water flow meter ?

Please tap the parameter screen and then tap "°F/°C" switch to toggle the unit.

WiFi SOCKET

Manual Power ON/OFF

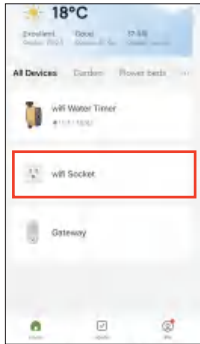

- 1) Tap the **WiFi Socket** on the all devices list of APP home screen.
- 2) Tap the **Power** to toggle the WiFi socket power on or off.

Note: Each RainPoint WiFi hub can be used as a WiFi socket. **But only when the WiFi timer is successfully paired with the WiFi hub, the WiFi socket device can be added to the APP.**

Power ON/OFF By Schedule

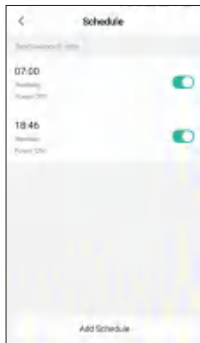
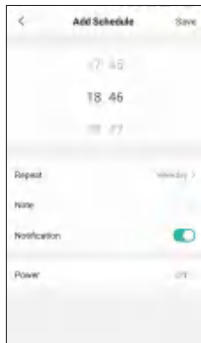

- 1) Tap the **Timer** on the WiFi Socket screen.
- 2) Tap the **Add Schedule** to set up a schedule for the WiFi Socket.
- 3) Use the clock wheels to set the desired switch time of day.
- 4) Tap **Repeat** to choose which days of the week to toggle the socket.

- 5) Tap **Note** to add a custom description to your schedule.
- 6) Toggle the Notification switch to receive alerts when the schedule is triggered.
- 7) Tap **Save** to set your schedule, or exit without saving.
- 8) The schedule of the WiFi socket will be displayed on the previous add schedule screen.

SMART AUTOMATION

Automation & Tap-to-Run

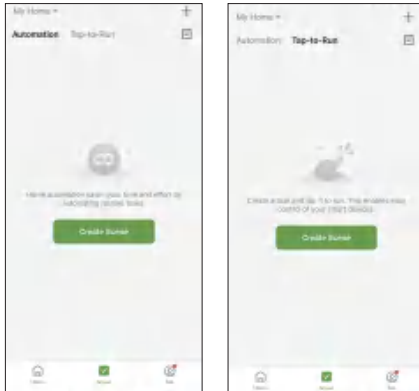

Automation means the devices can execute automatically according to the set conditions such as the local weather, device status and time.

For example: RAINPOINT APP can obtain the weather forecast information of your home location. When you set the conditions for immediately delaying the watering plan when it rains, the timer will automatically execute the watering delay when it rains in your local area. When you travel, you don't need to worry about whether the weather at home is raining.

Tap-to-Run means you can control multiple devices and plans with one tap.

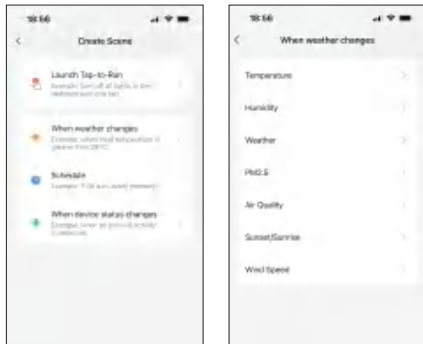

3 Steps To Set Automation Or Tap-To-Run

- 1) **Create scene:** According to your needs, set the conditions for automation or tap-to-run.
- 2) **Add task:** Set the tasks that the device needs to perform when the conditions are met.
- 3) **Save the settings:** Please remember to save all the settings. The device will automatically execute according to what you set.

How to set the automatic rain delay?

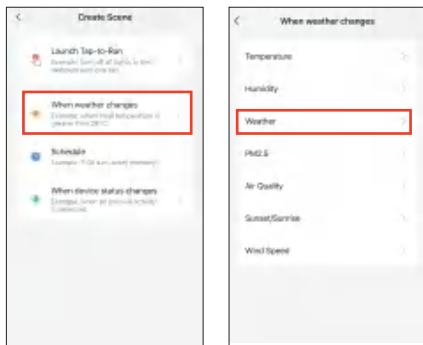

- 1) Tap **Scene** at the bottom of the APP home screen.
- 2) Select **Automation** and tap **Create Scene**.
- 3) Tap **"When weather changes"**, then select **"Weather"**; locate the city, then select **"Rainy"** and tap **"Next"** to continue.

Note: Please accurately locate the city where your home is located. The APP will automatically obtain weather forecast data based on the city you locate. When the weather forecast turns to rain, the conditions for execution will be triggered.

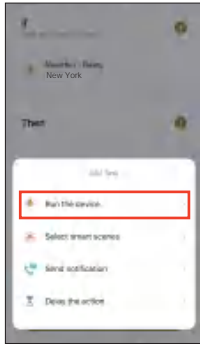

- 4) Tap "Add Task", select "Run the device" to set up a task about the device operation.
- 5) Select "Wifi Water Timer".
- 6) Select "Watering delay" and set the watering delay time and save, then tap "Next" on the upper right corner to continue.

Note: For the task to be performed by the device, select **Run the device**.

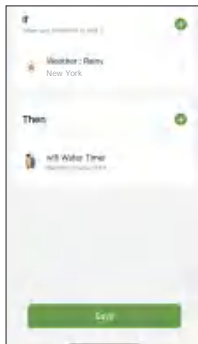
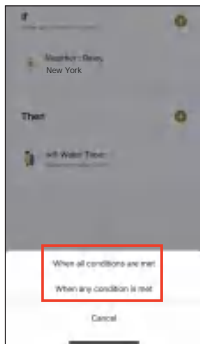

- 7) Select the trigger condition of your condition to be **When all conditions are met** or **When any condition is met**. If there is only one trigger condition, there is no need to set it here.
- 8) Check your execution conditions and tasks.
- 9) Save your settings.

For example: The picture on the left shows that when it rains in New York, the valve of the WiFi water timer will be automatically closed, and watering will be delayed for 24 hours.

HOME MANAGEMENT

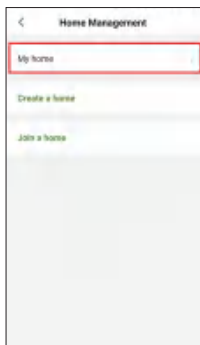
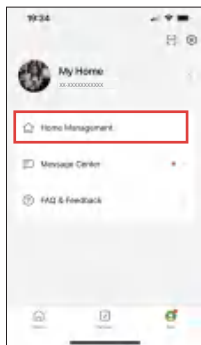

Rainpoint supports adding family members and sharing your home device to achieve co-management the home irrigation system with your family.

- 1) Tap **Me** at the bottom of the APP home screen.
- 2) Select **Home Management**. You can set the current home or create a home or join another home.

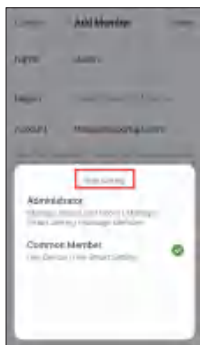
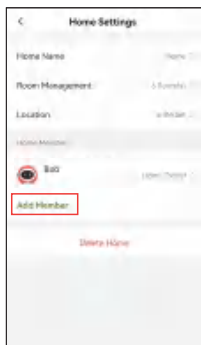

- 3) Set your **home name**, **room management** and **home location**.

Note: Home location is related to the weather forecast information obtained by the system.

- 4) Add **Home Member** and set the corresponding **usage permissions** for the members.

RESET THE DEVICE -----

HOW TO RESET THE WIFI HUB ?

Step 1: Press and hold the button. Please don't release until the end.

Step 2: Plug in the hub and wait for the BLUE light on (still keep holding the button).

Step 3: Keep holding the button. Wait for the BLUE light on for a few seconds and then rapidly flash, then the hub is restored to pair mode.

Search the link below to visit the WiFi Hub resetting video:

<https://youtu.be/ykucYsxRTTs>

HOW TO RESET THE WIFI TIMER ?

Step 1: Remove all batteries from the battery compartment.

Step 2: After 10 seconds, insert 4 fresh AA alkaline batteries into the battery compartment of the timer.

Step 3: While installing the battery, press and hold the button on the timer without releasing the button until the LED indicator quickly flashes (2 times per second), then the WiFi timer is restored to pair mode.

Search the link below to visit the WiFi Timer resetting video:

<https://www.youtube.com/watch?v=p-D0xTXZfTc>



Please scan the QR code below to get the resetting video quickly.

TROUBLESHOOTING

Problem	Possible Cause	Possible Solution
Can't turn on /off the valve	<ul style="list-style-type: none"> • Low battery. • Impurities in water inlet. • Unstable network or delayed response. 	<ul style="list-style-type: none"> • Replace fresh batteries. • Regularly clean the filter port of impurities to avoid disruptions in use. • Wait a while and try again.
Inaccurate water flow meter	<ul style="list-style-type: none"> • Inaccurate statistics due to tilted mounting angle. • Low or erratic water pressure from the tap. 	<ul style="list-style-type: none"> • The water timer needs to be installed perpendicular to the ground and it is not recommended that it is installed at any other angles to avoid affecting the water count. • Normal error values for water counts $\pm 5\%$.
Timer won't connect	<ul style="list-style-type: none"> • Unstable WiFi network. • Long distance from the hub. • Timer not in pairing mode. • The version of the timer is not compatible with the hub. 	<ul style="list-style-type: none"> • Check that the WiFi network environment is working. • Close to hubs and routers when connected to irrigation timers. • Re-pair the timer: Press and hold the timer button until the white light flashes rapidly to indicate pairing mode. (Or remove the device from the homepage and reconnect.)

Problem	Possible Cause	Possible Solution
		<ul style="list-style-type: none"> • Check that the difference between the version of the hub and the version of the timer is within two years. Normally, our products are updated with newer versions every year, so the difference between the hub version and the timer version should be no more than two years. If you are not sure about the version of your hub and timer, please feel free to contact us.
Hub cannot connect	<ul style="list-style-type: none"> • Not using 2.4GHz WiFi. • WiFi extender is open. • The router has been connected to the utmost number of devices it can support. • Incorrect WiFi password. • Hub not in pairing mode. 	<ul style="list-style-type: none"> • Confirm 2.4GHz WiFi connection. • Make sure all your WiFi extenders are closed. If you cannot confirm, please consult the internet company. • Make sure your router is not connecting to the utmost number of devices it can support and still has room to support another device. • Confirm that the WiFi password has been entered correctly.

Problem	Possible Cause	Possible Solution
		<ul style="list-style-type: none"> • Press and hold the middle button and insert it into the socket again without releasing the button, do not release the button during this time. After a few seconds the indicator light will come on for a while and then start flashing rapidly. This means that pairing mode has been entered.
Plan not executed on time	<ul style="list-style-type: none"> • Impurities in water inlet filter. • Rainfall delay parameters are set. • In a low power state, the timer goes into a low power protection state and does not execute the schedule. • Irrigation duration/period is not set with parameters. 	<ul style="list-style-type: none"> • Inlet impurities need to be cleared regularly so that they do not clog up and interfere with the irrigation programme. • Check that the rainfall delay parameter is set. • Replace fresh batteries. • Check that the irrigation duration/period is set with parameters. (Note 12H/24H)

If your Rainpoint product does not operate properly after trying the troubleshooting steps, please contact us by phone or email: US: +1-833-381-5659 | UK: +44-800-808-5337 | DE: +49-800-182-0576 | service@rainpointonline.com

THE MEANING OF LED LIGHT

LED indicator color of TTV103WRF WiFi water timer

- 1) **Power-on reset:** The red and white lights flash alternately 4 times when the machine is turned on.
- 2) **Restore factory settings:** Press and hold the timer button while turning on the timer, release the button after the red light flashes, and the timer will enter the factory reset state.
- 3) **Irrigation status:** The white light flashes for 3 seconds and lights for 200 milliseconds, indicating that the timer is in irrigation status.
- 4) **Water leakage alarm:** The red light flashes alternately for 1 second.
- 5) **Pairing state:** The white light flashes quickly (2 times per second) to indicate that the timer enters the timing pairing status, and waits for the 60-second pairing timeout to end.
- 6) **Low battery state:** The red light flashes for 3 seconds, and 200 milliseconds on indicates that the battery is in a low voltage state.

Power indicator color of TWG004WRF WiFi Hub

- 1) **Smart pairing status:** Blue LED light flashing fast (2 times per second).
- 2) **AP pairing status:** Blue LED light slow flashing.
- 3) **Socket function open:** Blue LED light is always on.
- 4) **Socket function off:** No light.

The meaning of App background color



Green means everything works well.

Red means the soil moisture is too high over the set level.

WARRANTY POLICY

RainPoint provides a **1-year warranty** against manufacturing defects in materials and workmanship from the date of purchase. During the warranty period, we'll replace free of charge the product found to be defective under reasonable use and service as determined solely by RainPoint. **To extend and activate your warranty**, please email us with your order ID at **service@rainpointonline.com** and we'll respond within 24 hours.

CUSTOMER SUPPORT -----



If you find it difficult to set up and want to watch the setting tutorial video, please subscribe to our channel: **RainPoint** on YouTube.

Please scan the QR code to visit the **RainPoint** channel on YouTube quickly.

If the app and the user manual don't have what you're looking for, and you need some help, please prepare the **Model NO.** and **LOT NO.** of your device and contact us before returning the product to the store.

US Free Hotline (English): +1 833-381-5659

(Mon-Fri: 9: 30 AM-5: 30 PM PST)

DE Free Hotline (English/Deutsch): +49 800-182-0576

(Mon-Fri: 9: 00 AM-5: 00 PM CET)

UK Free Hotline (English): +44 800-808-5337

(Mon-Fri: 9: 00 AM-5: 00 PM CET)

Email: service@rainpointonline.com

WhatsApp: +1626-780-5952

FCC NOTICE

FCC Statement: (FCC ID: 2AWDBTTV103WRF, 2AWDBTWG004WRF)

This device complies with Part 15 of the FCC Rules. Operation is subject to the following two conditions:

- 1) This device may not cause harmful interference.
- 2) This device must accept any interference received, including interference that may cause undesired operation.

FCC Warning: Any changes or modifications not expressly approved by the party responsible for compliance could void the user's authority to operate this equipment.

Note: This equipment has been tested and found to comply with the limits for a Class B digital device, pursuant to Part 15 of the FCC Rules. These limits are designed to provide reasonable protection against harmful interference in a residential installation. This equipment generates, uses, and can radiate radio frequency energy, and if not installed and used in accordance with the instructions, may cause harmful interference to radio communications. However, there is no guarantee that interference will not occur in a particular installation. If this equipment does cause harmful interference to radio or television reception, which can be determined by turning the equipment off and on, the user is encouraged to try to correct the interference by one of the following measures:

- Reorient or relocate the receiving antenna.
- Increase the separation between the equipment and the receiver.
- Connect the equipment into an outlet on a circuit different from that to which the receiver is connected.
- Consult the dealer or an experienced radio/TV technician for help.

Note: The manufacturer is not responsible for any radio or TV interference caused by unauthorized modifications to this equipment. Such modifications could void the user's authority to operate the equipment.

EC REP

NAME: VIAJE ELECTRONIC COMPANY LIMITED

ADDRESS: E588, 13 ADELAIDE ROAD, DUBLIN, D02 P950, IRELAND

Email: VIAJEELE@OUTLOOK.COM

UK REP

NAME: SUJE ELECTRONIC COMPANY LIMITED

ADDRESS: S211 92A BURY OLD ROAD, MANCHESTER, ENGLAND, M45 6TO

EMAIL: SUJEELECTRONIC@OUTLOOK.COM

Manufacturer/Hersteller/Fabricant/Produttore/Fabricante:

FUJIAN BALDR TECHNOLOGY CO.,LTD

ADDRESS/ADRESSE/ADRESSE/INDIRIZZO/DIRECCION:

Floor 3, Building 2, No.71 Yangqi Road, Fuwan Industrial Area, Cangshan District, Fuzhou, China.350008

EMAIL: service@rainpointonline.com



ÉLÉMENTS D'EMBALLAGE
À SÉPARER ET À DÉPOSER
DANS LE BAC DE TRI



FR

Cet appareil
se recycle

À DÉPOSER
EN MAGASINÀ DÉPOSER
EN DÉCHÈTERIE

OU



Points de collecte sur www.quefairedemesdechets.fr
Privilégiez la réparation ou le don de votre appareil !



Made in China

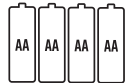

Not included



Scan the QR code to
get fast support

Need Help?

Please contact us

US toll free: +1 833-381-5659

(Mon-Fri: 9:30 AM-5:30 PM PST)

DE toll free: +49 800-182-0576

(Mon-Fri: 9:00 AM-5:00 PM CET)

UK toll free: +44 800-808-5337

(Mon-Fri: 9:00 AM-5:00 PM CET)

Email: service@rainpointonline.com

WhatsApp: +1 626-780-5952