

USER MANUAL

Wired Rain Sensor

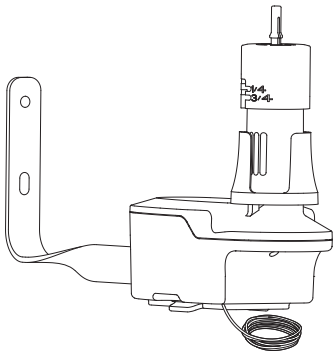

Model No.: ICS044DC



Email

service@rainpointonline.com



Hotline

US: +1 833-381-5659

DE: +49 800-182-0576

UK: +44 20-4628-3036

1. INTRODUCTION

1.1 Product Overview

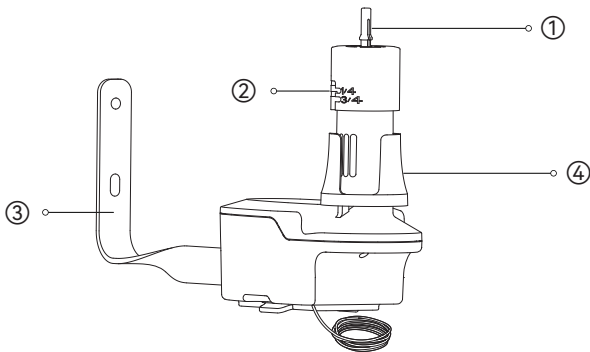

1. **Manual Test Lever:** Used to manually trigger the rain sensor to verify proper connection with the timer.
2. **Rainfall Threshold Selector:** Used to select the rainfall threshold. When the detected rainfall reaches the selected level, the timer will not operate.
3. **Mounting Bracket:** Used to mount and secure the device in place.
4. **Vent Shield Ring:** Rotates to change the degree of vent shielding, thereby affecting the evaporation rate. Greater shielding slows evaporation, while less shielding allows faster evaporation. This component does not completely block airflow.

1.2 Feature Overview

- **Automatic Rain Delay:** When rainfall is detected, the timer automatically suspends the watering schedule after approximately 5 minutes.
- **Automatic Resume:** After rainfall stops, the hygroscopic disc begins to dry naturally. Once the disc dries to operating condition, the watering schedule automatically resumes.
- **Evaporation Control:** By rotating the vent shield ring, the drying speed of the hygroscopic disc can be adjusted, thereby controlling the system recovery time.
- **Adjustable Rainfall Threshold:** The rainfall level required to suspend watering can be selected as shown below.

| Rainfall Threshold | Imperial | Metric |
|--------------------|----------|--------|
| Level 1 | 1/8 in | 3 mm |
| Level 2 | 1/4 in | 6 mm |
| Level 3 | 1/2 in | 13 mm |
| Level 4 | 3/4 in | 19 mm |

2. INSTALLATION AND IMPORTANT NOTES

①

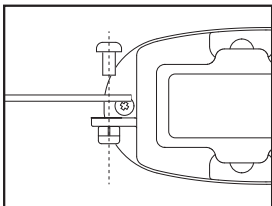

②

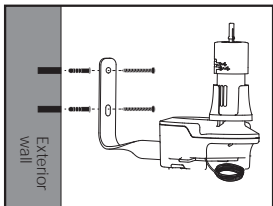

1. Use a screwdriver (not included) to tighten the screw and connect the mounting bracket to the sensor. The nut is pre-installed.
2. Install the rain sensor in a high, open location to allow rainfall to fall directly onto the sensor.
3. Do not install the sensor in areas exposed to sprinkler spray or other sources of dripping water.
4. Ensure the sensor body remains upright during installation.
5. If angle adjustment is needed, loosen the locking nut, adjust the sensor to the desired angle, and retighten the nut securely.

3. COMPATIBLE RAINPOINT TIMERS

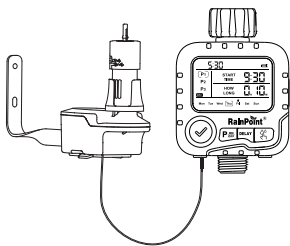

ITV156

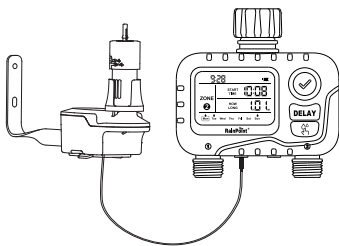

ITV256

1. Locate the DC connection port marked with the  icon on the bottom of the timer. Open the waterproof cap and plug the connector into the port.

Note: When the rain sensor is not in use, reinstall the waterproof plug to protect the port.

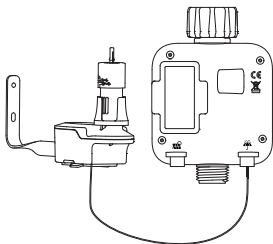

ITV156

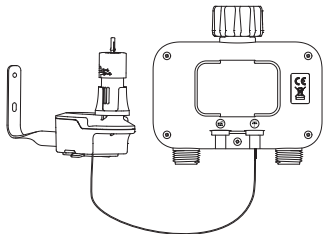

ITV256

2. Press the Manual Test Lever. If the  icon appears on the timer display (as shown below), the connection is successful.

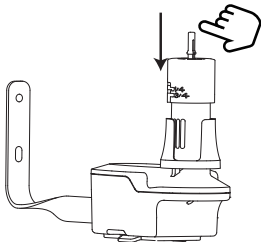

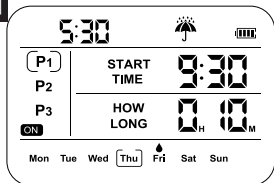

ITV156

Rain Sensor Connected Display

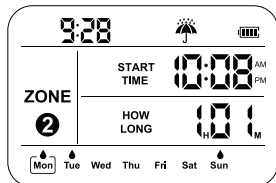

ITV256

Rain Sensor Connected Display

4. TROUBLESHOOTING

| ISSUE | SOLUTION |
|----------------------------|--|
| Rain sensor dose not work. | <ul style="list-style-type: none"> • Press the top of the Manual Test Lever and check whether the  icon appears on the timer display to verify that the rain sensor is properly connected and functioning. • Select a different rainfall threshold and test again to confirm whether the current threshold setting is suitable for the actual rainfall conditions. • Check for obstructions that may block rainfall, such as overhangs, trees, or walls. |

5. WARRANTY POLICY

RainPoint provides a 1-year warranty against manufacturing defects in materials and workmanship from the date of purchase. During the warranty period, products found to be defective under normal use and service, as determined solely by RainPoint, will be replaced free of charge.

To request warranty service, email your order ID to service@rainpointonline.com. A response will be provided within 24 hours on working days.

6. CUSTOMER SUPPORT

For setup difficulties, search "**RainPoint**" on YouTube to view installation videos. If the required information is not found in this user manual or if further assistance is needed, contact customer support before returning the product to the store. The local customer support team will provide a solution within 24 hours on working days and may arrange a replacement or refund where applicable.

For efficient support, please provide the following information:

- Order number
- LOT NO. of the device
- Brief description of the problem

Contact information:

US Hotline: +1 833-381-5659

DE Hotline: +49 800-182-0576

UK Hotline: +44 20-4628-3036

Email: service@rainpointonline.com

EC REP

NAME: VIAJE ELECTRONIC COMPANY LIMITED

ADDRESS: E588, 13 ADELAIDE ROAD, DUBLIN, D02 P950, IRELAND

EMAIL: VIAJEELE@outlook.com

UK REP

NAME: SUJE ELECTRONIC COMPANY LIMITED

ADDRESS: S211 92a Bury Old Road, Manchester, England, M45 6TQ

EMAIL: SUJEELECTRONIC@outlook.com

Manufacturer/Hersteller/Fabricant/Produttore/Fabricante:

FUJIAN BALDR TECHNOLOGY CO.,LTD

ADDRESS/ADRESSE/ADRESSE/INDIRIZZO/DIRECCIÓN:

Floor 3, Building 2, No.71 Yangqi Road, Fuwan Industrial Area,
Cangshan District, Fuzhou, China. 350008

EMAIL:service@rainpointonline.com

